

# **Puffin Sport and Saco**

Assembly and  
User Information

## **Pakboats/ScanSport, Inc.**

Post Office Box 700 May Street Enfield,  
New Hampshire 03748 USA Phone:  
(888) 863-9500 (toll free) From outside  
the US: +1 (603) 632-9500 Fax: (603)  
632-5611 Email: [info@pakboats.com](mailto:info@pakboats.com)  
[www.pakboats.com](http://www.pakboats.com)



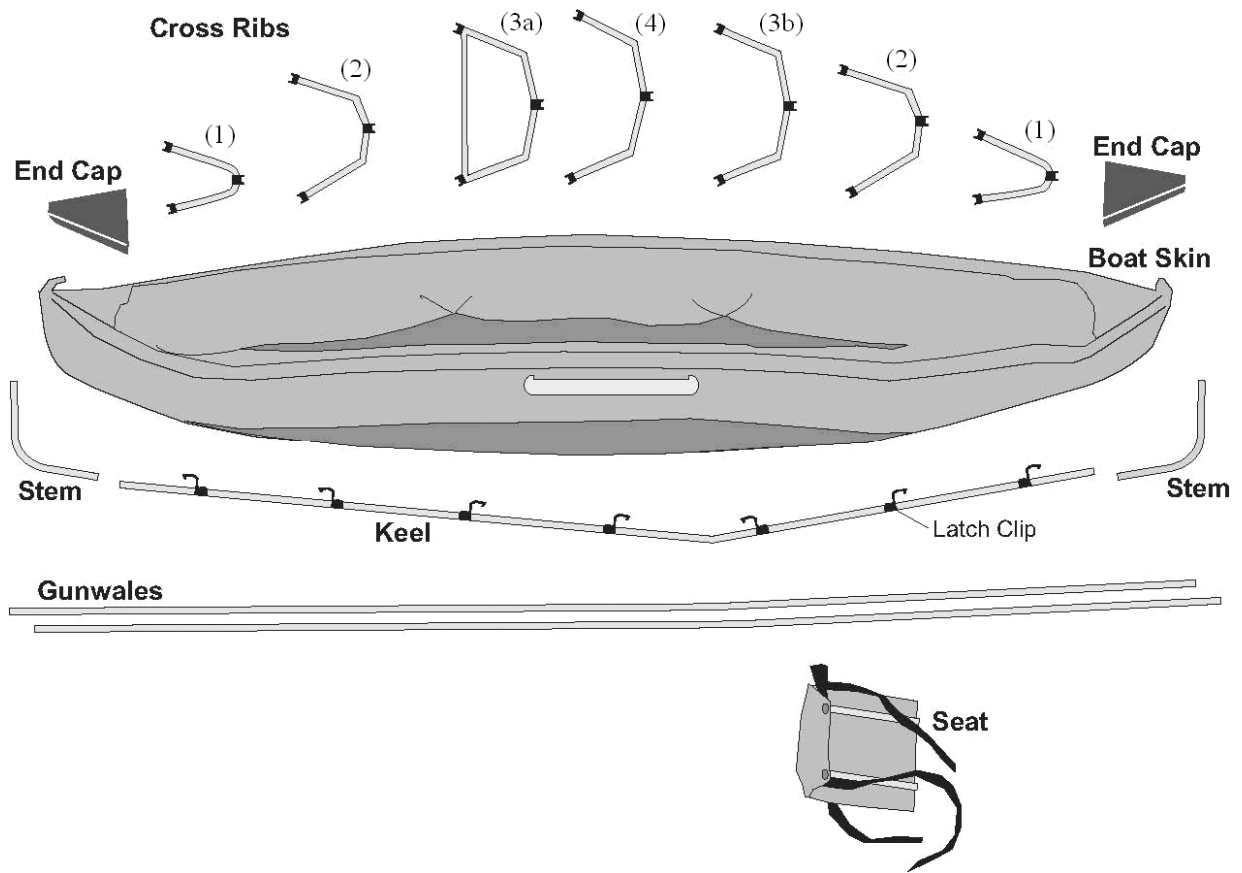

Figure 1, Parts

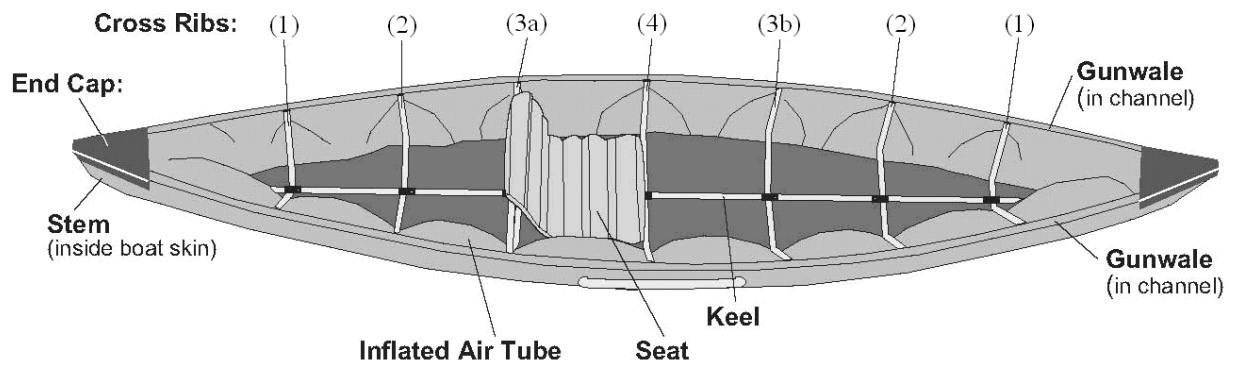

Figure 2, Assembled

# Assembling the Puffin Sport or Puffin Saco

**NOTE!** We recommend that you study this manual carefully before you start the assembly procedure! When assembling the Puffin Sport or the Puffin Saco, please refer to Figure 1 and Figure 2 of this manual.

1. Roll out the *boat skin* and assemble all the rods.
2. Insert both *gunwales* as far as they will go.
3. Close the flaps to cover the ends.
4. Assemble *keel* and *stems*.
5. Position *keel* and *stems* inside the boat skin.

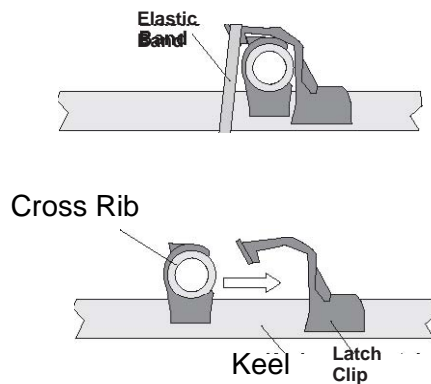

Figure 3, Latch Clip

6. Mount *cross rib (4)*.
7. Mount *cross ribs (3A) and (3B)*.
8. Mount the four remaining *crossribs, (1) and (2)*.

- The sections of the long rods are internally connected by elastic cords to ensure correct assembly.
- The two longest rods are *gunwales*. They are to be inserted in channels along the edges of the *boat skin*. The channel openings are under flaps at one end of the skin.
- The curved pieces without plastic fittings are *stems*. The narrow end of the *stems* fit into the *keel*.
- The *keel* will now be at an angle.
- The top of the *stems* should clip securely to tube stubs attached to the boat skin at each end.
- The *cross ribs* are connected to the *keel* by means of *latch clips*. Each *cross rib* has a plastic clip at the center. Position this clip on the keel as shown in Figure 3 and press in the direction of the arrow until the *latch clip* locks. Mount the *elastic band* to secure the locking.
- The ends of the *cross rib* clip to the *gunwales* at openings in the *gunwale channels*.

- *Cross rib (4)* is the widest one and will be installed at the center of the Puffin. To install it the keel angle is moved to the center of the boat.
  - **As the cross ribs are installed the keel will gradually straighten.**
- NOTE:** The hull is symmetrical. It does not matter at which end *cross ribs (3A)* and *(3B)* are installed.
- Make sure the *stems* are centered in the *boat skin*.
  - The rear part of the Puffin will now be where *rib (3A)* is installed.
  - Make sure the *keel* is straight and the *stems* are still centered in the ends of the *boat skin*.

**9. Inflate both *air tubes* alternately until they feel hard (about as much as a fit person could do by mouth).**

- Make sure the *keel* is positioned between the lines in the bottom of the *boat skin*.

**10. Install the black fabric *end caps*.**

- The *end caps* are installed at both ends of the boat by means of Velcro fasteners.

**11. Inflate the *seat*.**

**12. Mount the *seat*.**

- The *seat* is placed with the metal frame against *cross rib (3A)*.
- Secure to the center *cross rib (4)* with the two short snap straps at each forward corner.

***The Puffin is now complete***

## Disassembling the Puffin Sport or Saco

*Disassembling is essentially the assembly process in reverse, but there are a few important details:*

- **To remove the *gunwales*:**
- **Open the flaps and lift the *gunwale ends* free of the *boat skin*.**
  - **Move to the other end of the boat and grip the side fabric on one side just below the *gunwale*, about a foot (30 cm) from the end.**
  - **Push with the other hand against the end of the *gunwale*.**
  - **Straighten the *boat skin*, move your hands, and repeat the process on both sides of the boat until the *gunwales* can easily be pulled out. *It is helpful to make the gunwales curve like in the assembled boat when pulled out.***

*NOTE!* If some *gunwale sections* disconnect, you can still pull the *gunwales* out, but it is then important to stretch the *boat skin* so the *gunwale channels* are straight.

- **Open the *air tube valves* and roll up the *boat skin* from the end opposite the *valves*.**

## Some general information about your Puffin

### Patches and Reinforcements

Punctures and abrasions to the **boat skin** are easily repaired with the enclosed repair kit.

- Cut a patch to cover the damaged area plus  $\frac{3}{4}$ " around it.
- Round the corners of the patch.
- Clean the patch and the area to be covered. Apply a thin coat of adhesive to both surfaces.
- Wait until the adhesive feels dry and apply the patch. Make sure the surfaces are pressed together well. *Note: The smooth side of the patch should face out.*

The Puffin can be used immediately after the repair, but the bond will gradually strengthen for 24 hours.

You can add reinforcement to wear areas. After some use it is easy to see which areas are exposed to wear. Simply install patches of the same color fabric.

Punctures of the **inflatable tubes** can be repaired with the adhesive in the repair kit and a patch. The patch material in the repair kit can be used on the air tubes as well. Follow the above procedure. It is important to clean the surfaces well before applying the adhesive.

**Note:** *Adhesives work best on rough surfaces. We recommend using fine sandpaper before adhesives are applied.*

**Note:** *If you use 303 Protectant or similar product to protect your Puffin against harmful UV rays, you have to remove the protectant completely before attempting to apply a patch.*

**Note:** *Heat from the sun can cause increased pressure in inflatable parts. To avoid damage, you should pay attention to how hard your flotation tubes become, and let out some air to relieve the pressure if you suspect that the tubes are getting too hard.*