

NERIS *Alu 3*

Instructions Manual

Folding Kayak NERIS ALU-3

1. General Description

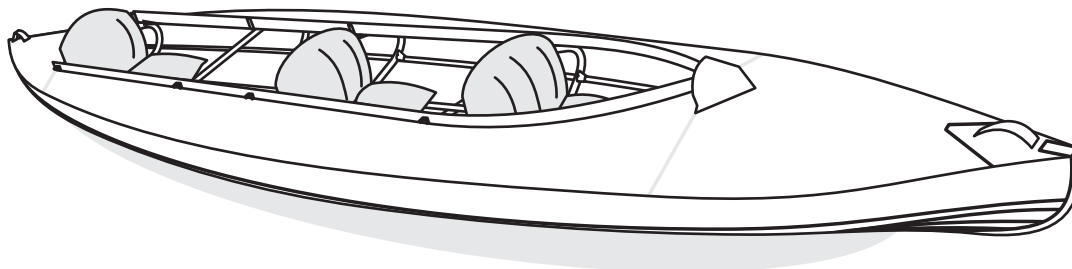

NERIS Alu-3 is a touring folding kayak ideal for flat water trips on rivers, lakes and water reservoirs. It is also suitable for sea and ocean kayaking along shore line.

The light weight and compact size are the main advantages of the NERIS Alu-3 folding kayak providing paddlers ease in transporting and use.

The kayak assembly or disassembly time is within 20-25 minutes. No additional tools are required. The framing of the kayak provides required stiffness and shape to have great paddling experience.

Technical specifications:

| | |
|------------------|--------|
| Loading capacity | 375 kg |
| Length | 5,7 m |
| Width | 0.88 m |
| Weight | 29 kg |

Packaging size:

| | |
|---------------|------------------|
| Backpack (mm) | 500 x 900 x 230 |
| Bag (mm) | 1100 x 230 x 230 |

Number of passengers: 2 or 3 adults
or 2 adults and 1-2 children.

2. Bag's Content

1. Set of Cross Ribs - 5 pcs
2. Bow and Stern Assembly
3. Bow, Stern A-Shape and Middle Keel Bars - 4 pcs
4. Set of Gunwales
 - a. Long gunwales - 12 pcs
 - b. Short gunwales - 12 pcs
 - c. Middle gunwales - 6 pcs
5. Set of Washboards - 8 pcs
6. Skin
7. Seats - 3 pcs
8. Backpack and bag
9. Repair Kit

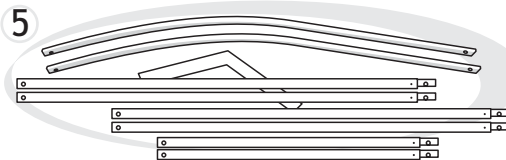
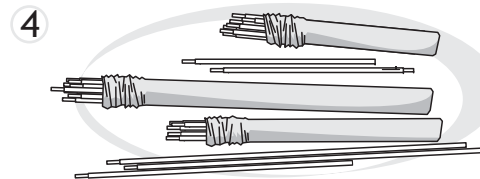
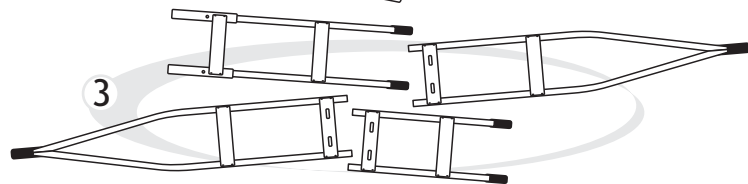
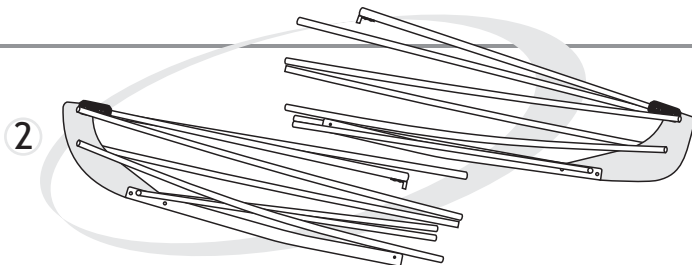
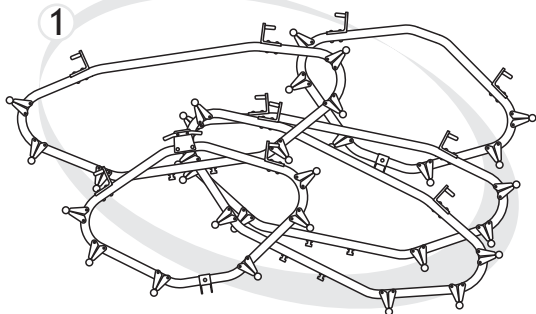

3. Assembly Instructions



All NERIS folding kayaks are run through presale test assembly. However, the first kayak assembly may seem to be more challenging than following one. The skin is being stretched with each assembly and it will be easier to put the skin on a frame.

Two people kayak assembly is recommended. The kayak is to be assembled on even and clean surface. Avoid assembling the kayak on sand. It may cause damage to joining parts and more difficult assembly and disassembly in future.

The main parts of the kayak are marked with numbers and pointing arrows for ease of assembly. The Keel Bars are marked showing points where the Cross Ribs are to be installed.

Step 1.

Attach Bow and Stern A-shape Keel Bars to Bow and Stern Assembly. Attach Cross Rib #1 and #5 to Bow and Stern Assembly. Use wing nuts and bolts to secure the cross ribs. The kayak features seamed cross ribs with stainless steel brackets. Note that brackets on Cross Rib #1 must lean towards the bow. The brackets on Cross Rib #5 must lean towards the stern. The right-hand washboards have number indications to match the numbers on the cross ribs.

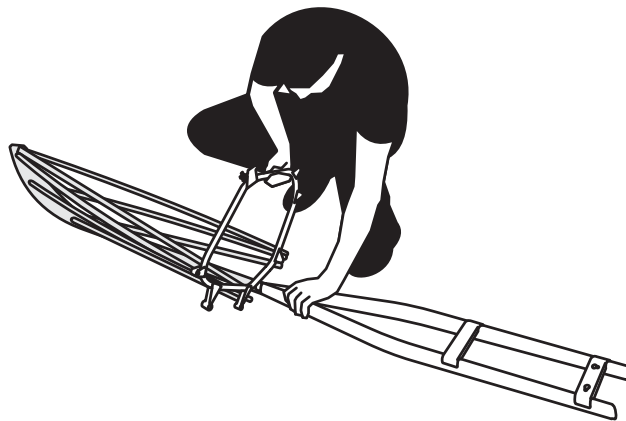

3. Assembly Instructions

Step 2.

Position gunwales (female) of Bow Assembly next to cross rib bracket rings. Insert 6 long gunwales one by one into Bow Assembly through the bracket rings until complete stop. Repeat this step for attaching remaining 6 long gunwales to Stern Assembly. The bow and stern sections are ready to be inserted in to a skin.

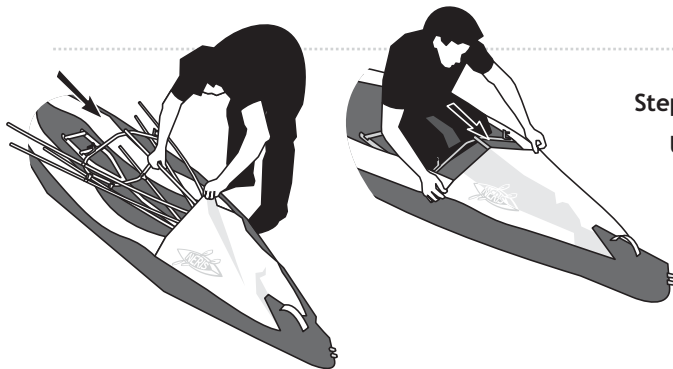
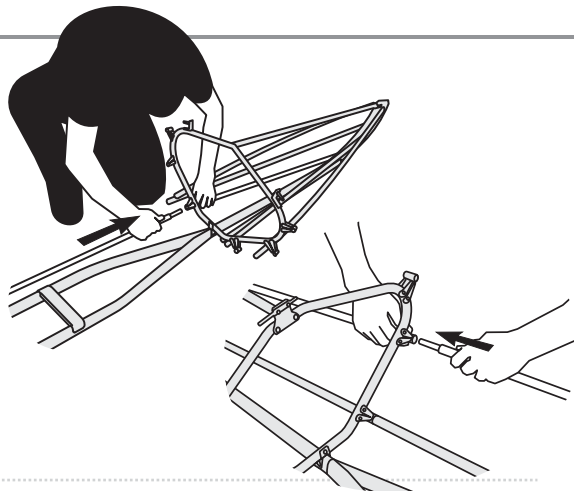

Step 3.

Unroll the skin. Insert bow and stern assembly sections in to the skin (NERIS logo is marked on stern of the skin). Make sure that the stitch line between deck and hull is positioned just above the upper gunwale. Avoid possible tilt of bow and stern sections while putting them inside the skin.

Step 4.

1. Extend Stern A-shape Keel Bar with Middle Keel Bars (short and long). Shorter Middle Keel Bar section must be installed before longer section.

2. Lift middle parts of bow and stern sections. Position Keel Bar female and male sleeves and slowly push Keel Bar down. This procedure is important to ensure the proper secured Keel Bar structure and stretch the skin lengthwise.

3. Install Cross Rib #2, #3 and #4. Insert one of the lower cross rib caps in to cross-cut slot of the keel bar plate. While lifting, rotate the Cross Rib and position the second cap against for-and-aft slot. Insert cap and twist Cross-Rib to have caps securely in place.

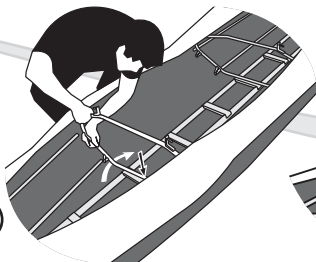
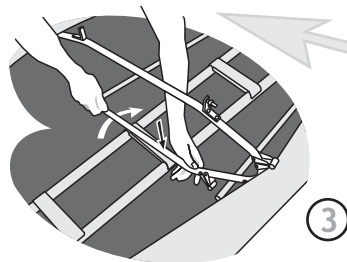
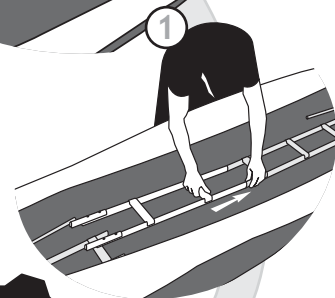
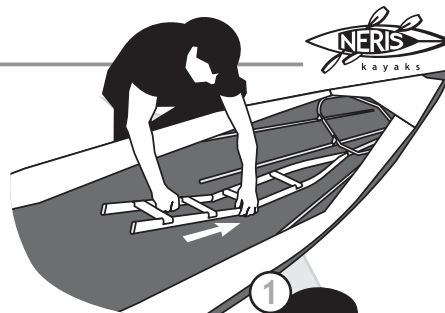

3. Assembly Instructions

Step 5.

Repeat step 2 to install middle gunwales into Cross Rib#4. Insert 12 short gunwales one by one into Cross Ribs #3 and #2. Using latches, secure all short gunwales one by one starting from the lower gunwales. The upper gunwales are to be locked last. In order to connect gunwales, lift them a little and insert male latch connector with female gunwale. Slowly straighten gunwales and lock the latch.

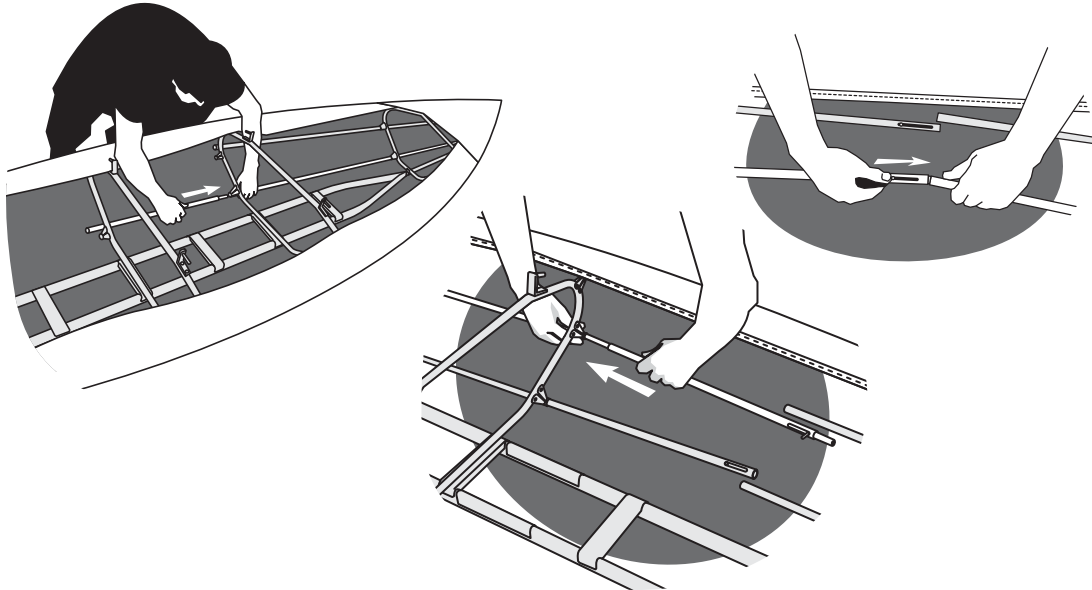

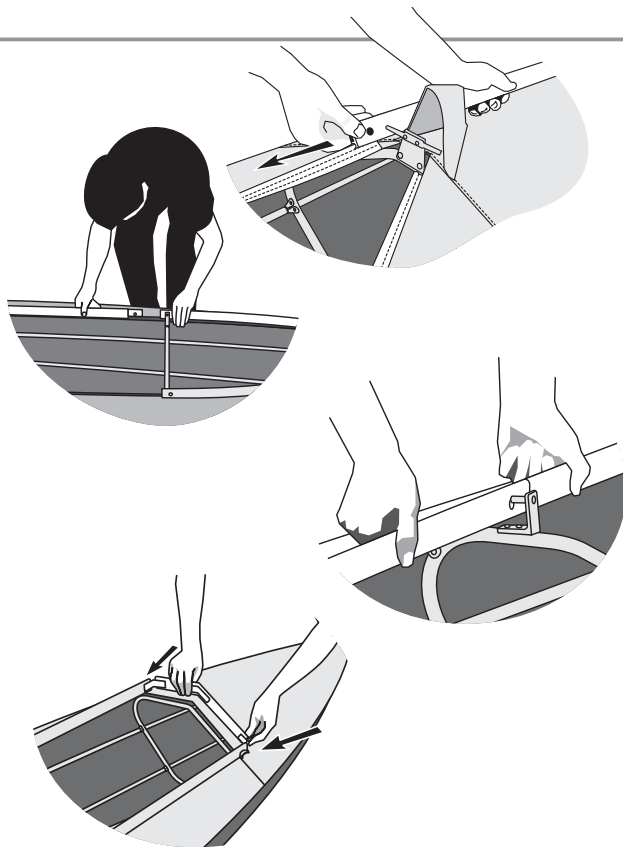

Step 6.

Install the washboards. Before installing the washboards replace the wing nuts from U-bolts on Cross Ribs. Insert the round rope skin edge into the open end of the grooved channel at the bottom of the washboard sections. Engage curved bow section of the washboard from the bow and rear section from the stern according to number marks. Meet the washboard holes with the U-bolts of Cross Ribs. Secure the washboard sections by wing nuts. Make sure the first and last washboard holes are secured first. Then proceed with other sections.

Two people are recommended to complete this step. The first person pulls the washboard in place. The other person puts the wing nut on. When all wing nuts are in place tight them up securely.

3. Assembly Instructions

Step 7.

The front seat is to be strapped between Cross Ribs #1 and #2. The middle seat is positioned between Cross Ribs #2 and #3, and the rear seat is strapped between Cross Ribs #4 and #5.

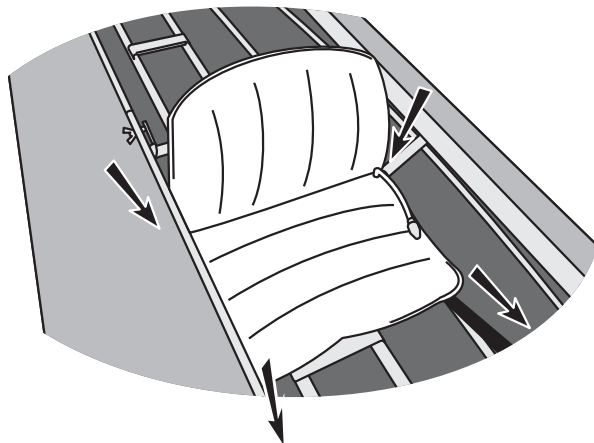

The kayak is ready to go!

4. Additional Information

Unfolded kayak packaging.

To ensure long life of the folding kayak the proper packaging is required. When the skin is free of the frame remove dirt, grit and other objects. Spread the skin and dry out. Follow the steps on the diagram below to pack the skin and Cross Ribs. Include the seats, repair kit and other accessories as spay deck and skirts in the backpack in addition to the skin. All Keel Bar parts and Bow and Stern Assembly are to be packed last.

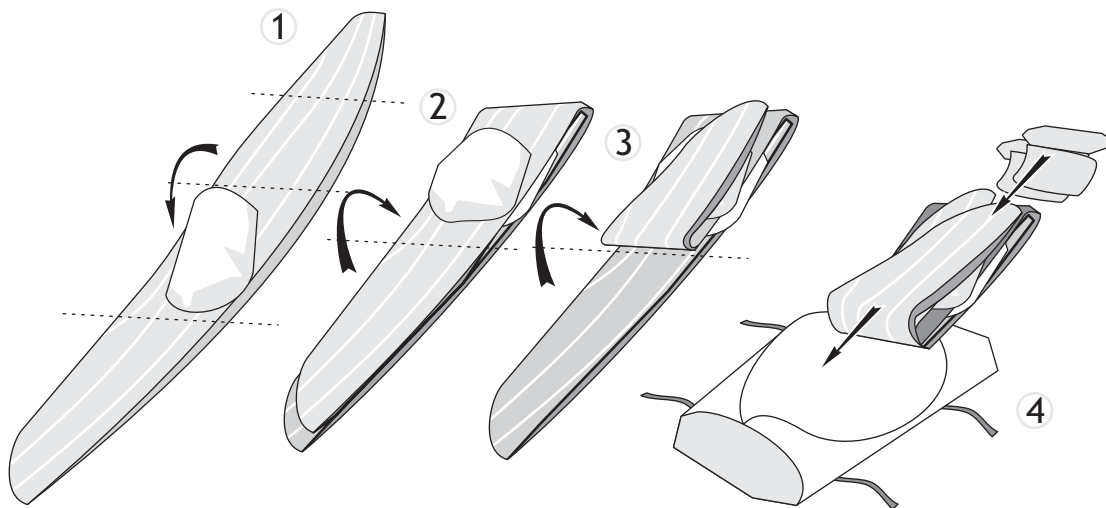

Storage and maintenance of the kayak.

When done paddling ensure that Cross Ribs and Skin are dried out. If used on sea waters, all parts of the kayak must be rinsed off with fresh water.

It is recommended to store the kayak inside in dry and warm conditions. But skin and other aluminum parts can be stored either in garage and/or locker.

It is not desirable to move the skin while storing it at low temperatures. Skin repair instructions can be found on www.neriskayaks.com FAQ

Manufacturer's Warrantee.

NERIS LTD. the manufacturer guarantees suitability and kayak material quality under condition that the assembly instructions have been followed. The manufacturing company will repair free within 36 months of use from the date of purchase should there be manufacturer's defects. You also can address any repair issues as a result of hitting rocks or wrong assembly during warrantee periods and later. However, kayak owner will bear the repair costs.

Contact us

Contact NERIS Ltd. for any suggestions and questions not revealed in this instructions manual.

.....
Kayak Serial Number:

Date manufactured:

President of NERIS Ltd

Konstantin Abramov



NERIS Ltd., 2 Bukaevitsa Street, Starye Pertovtsy Village
Vyshgorod District, Kiev Rigion, Ukraine

tel.: (+380-44) 228-0-228
website: www.neriskayaks.com
e-mail: info@neriskayaks.com

